



**1TM-4**  
**1" MYLARTWEETER**  
**WITH 1/2" VOICE COIL**  
**4 OHM**

**FEATURES**

- Rugged 1" Mylar diaphragm
- Lightweight and agile 1/2" voice coil
- Round injection-molded faceplate with phase shield
- Extremely commonly tweeter found in many designs
- Great replacement speaker

**PARAMETERS**

|                               |                   |
|-------------------------------|-------------------|
| Impedance                     | 4 ohms            |
| Re                            | 3.5 ohms          |
| Le                            | .1 mH             |
| Fs                            | 3,000 Hz          |
| Qms                           | -                 |
| Qes                           | -                 |
| Qts                           | -                 |
| Mms                           | -                 |
| Cms                           | -                 |
| Sd                            | -                 |
| Vd                            | -                 |
| BL                            | -                 |
| Vas                           | -                 |
| Xmax                          | -                 |
| VC Diameter                   | 13 mm             |
| SPL                           | 90 dB @ 2.83V/1m  |
| RMS Power Handling (AES 426B) | 5 watts           |
| Usable Frequency Range (Hz)   | 4,800 - 20,000 Hz |

**MECHANICAL DRAWING**

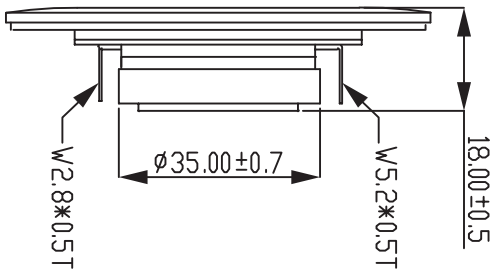
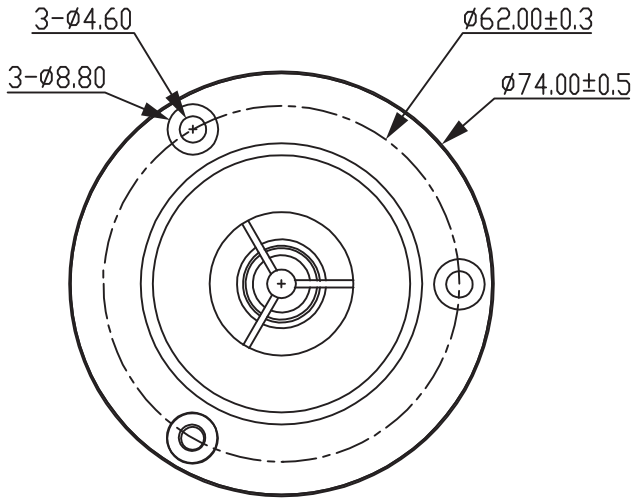

**IMPEDANCE/PHASE**

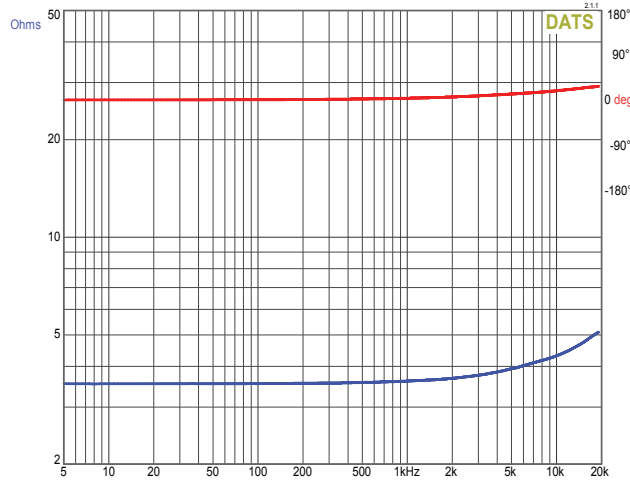

**FREQUENCY RESPONSE**

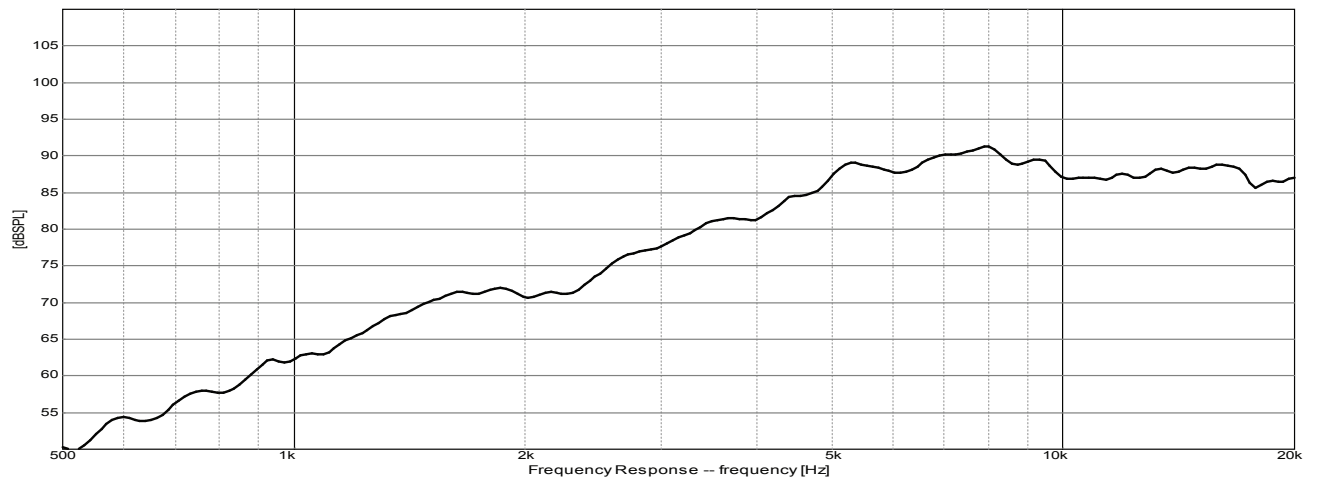

Note: 1/24<sup>th</sup> octave smoothing - nearfield response included in graph below 450 Hz.